

Hyperchill Plus

Industrial Water Chillers
for Precision Cooling



Short description

Extremely compact and easy to use, Hyperchill Plus is designed for safe and reliable operation in the most varied working conditions, providing a precise and accurate control of the process fluid temperature. The availability of a wide range of accessories and options makes Hyperchill Plus a very flexible solution that fits the needs of all industrial applications.

Thanks to a non-ferrous hydraulic circuit, Hyperchill Plus ensures stable working conditions with maximum quality and cleanliness of the cooling fluid (water, water-glycol mixture, low viscosity fluids), improving the efficiency and productivity of the process and greatly reducing maintenance costs and plant downtime.

Each individual Hyperchill Plus unit is extensively tested to guarantee efficient operation and reliability in all working conditions.



Process cooling applications:

- Coating Systems
- Chemical & Pharmaceutical Processes
- Plastics Processing
- Thermoform Machines
- Plasma Coating
- Medical Imaging Systems
- Food & Beverage Industry
- Injection Moulding
- Machine Tools
- Electroplating Baths
- Biogas & Natural Gas Treatment
- Compressed Air Treatment
- Laser Technology
- Extruders
- Surface Processing
- Welding Engineering
- Blow Mould Machines
- Flexographic Printing Systems

Product Specification

Hyperchill Plus Water Range

Customer Benefits

- A differential pressure switch ensures a system shut down in the case that the circuit runs dry. Therefore the customers investment is protected.
- Because of its compact design the Hyperchill Plus provides a space saving and easy to install solution.
- Condenser filters reduce dirt, thereby preventing system downtime.
- Reliable operation even in extreme ambient conditions. The standard units allow maximum ambient temperatures up to 48 °C. The tropicalized units up to 53 °C.
- The non-ferrous hydraulic circuit maintains the quality of the coolant ensuring stable working conditions, improving productivity and decreasing maintenance costs.

Product Features

Complete solution, easy to install and manage

- **Non ferrous hydraulic circuit:** non-ferrous water tank (stainless steel from ICEP005), stainless steel plate evaporator, non-ferrous pump with bypass prevent water from becoming corrosive.
- **Pump and tank installed inside the chiller** provides a compact and easy to install solution; without pump and/or without tank solution available.
- **Electronic controllers with proprietary software** provide access to all the parameters of the units and allow special management for any specific need, with remote monitoring available.
- **Completely configurable** with many options and kits to fit the needs of industrial applications.
- **Condenser filters** reduce dirt, thereby preventing system downtime.
- As standard installed **differential pressure switch** that makes sure that the systems shuts down in the case that the circuit runs dry. Therefore the investment is protected.
- **Designed with eyebolts** (till ICEP014) for easy handling.
- **IP54 standard** from ICEP007 for outdoor installations.
- **Independent condensing plenum** enables routine and special maintenance to be performed without stopping the system.
- Unit structure and design guarantee **full internal access** for easy maintenance.
- ICEP020 and ICEP024 designed with **fan step control** in order to work in low ambient temperatures down to -10 °C.
- **RS485 card** available on all models (standard from ICEP007).
- **Water and refrigerant manometers** permit full control of the working conditions.
- **Water pump: (standard 3bar) different head-pressures** available to meet the requirements of specific applications.
- **Visual level Indicator:** designed for open circuit models ICEP002, ICEP003, ICEP005.
- High reliability & Low energy consumption
- **Large built-in water tank** that provides a large thermal mass / storage capacity thus reducing the number of refrigerant compressor stop/starts and short cycling thereby increasing the compressor and chiller lifetime and reducing the energy consumption.
- **Maximum ambient temperature up to 48 °C** on standard units, **Tropicalization up to 53 °C** and Low ambient options ensure reliable operation in extreme ambient conditions.
- **Oversized condensers and evaporators** guarantee high performing heat exchange increasing COP (Coefficient Of Performance).
- **PID software developed and tested** to give the highest temperature consistency even at variable loads.
- Use of **compliant scroll compressors** (from ICEP007) designed specifically for high efficiency and long life in industrial applications.
- **Low ambient speed-control** (optional) on fan-motor ensures constant performances at different temperatures, long lifetime of the fans and a reduction in absorbed power when ambient temperature is low.

Product Specification

Hyperchill Plus Water Range

Hyperchill Plus Water Range

Model ICEP		002-W	003-W	005-W	007-W	010-W	014-W	020-W	024-W
Cooling capacity ¹	kW	1,7	3,3	5,2	7,8	10,8	14,6	20,3	23,6
Compressor abs. power ¹	kW	0,7	1,3	1,4	1,7	2,5	3,2	4,4	5,4
Cooling capacity ²	kW	1,3	2,3	3,7	5,8	7,9	10,6	14,6	17,2
Compressor abs. power ²	kW	0,7	1,2	1,3	1,8	2,7	2,8	4,3	5,8
Power supply	V/ph/Hz	230/1/50				400/3/50			
Protection index		33				54			
Refrigerant		R407c							

Compressor

Type		hermetic pistons				scroll			
Compressors / circuit		1 / 1							
Max.abs. power ¹ compressor	kW	0,7	1,3	1,5	2,4	3,8	4,4	5,7	6,6

Axial fans

Quantity	n.°	1	1	1	1	1	1	2	2
Max. abs. power ¹ fan	kW	0,07	0,12	0,12	0,3	0,3	0,4	0,4	0,4
Air flow	m ³ /h	430	1295	1295	3437	3437	4337	6878	6159

Water cooled version

Condenser water flow	m ³ /h	N.A.				1,5	2,1	2,5
Condenser connections	in	N.A.				3/4"	3/4"	3/4"

Pump P30

Max.abs.power	kW	0,4	0,4	0,4	0,9	0,9	1,0	1,3	1,3
Water flow (nom. / max) ¹	m ³ /h	0,3 / 1,9	0,6 / 1,9	0,9 / 1,9	1,3 / 4,8	1,8 / 4,8	2,5 / 6	3,4 / 9,6	4,9 / 9,6
Head pressure (nom. / max) ¹	m H ₂ O	35/5	33/5	26 / 5	30 / 12,8	29 / 12,8	29 / 21	29 / 17,3	28 / 17,3
Water flow (nom. / max) ²	m ³ /h	0,2 / 1,9	0,4 / 1,9	0,8 / 1,9	1,0 / 4,8	1,3 / 4,8	1,8 / 6	2,5 / 9,6	2,9 / 9,6
Head pressure (nom. / max) ²	m H ₂ O	36 / 5	32 / 5	27 / 5	32 / 12,8	30 / 12,8	31 / 21	30 / 17,3	29 / 17,3

Dimension and weight

Width	mm	520	755	755	756	756	756	756	756
Depth	mm	500	535	535	806	806	806	1206	1206
Height	mm	550	801	801	1405	1405	1405	1405	1405
Connections in/out	in	1/2"	3/4"	3/4"	3/4"	3/4"	3/4"	1"	1"
Tank capacity	l	15	15	22,5	65	65	65	100	100
Weight (axial)	kg	40	80	85	160	165	175	220	230
Weight (water cooled)	kg	n/a	n/a	n/a	n/a	n/a	175	220	230

Noise level

Sound pressure (axial) ³	dB(A)	52	52	52	53	53	50	50	50
-------------------------------------	-------	----	----	----	----	----	----	----	----

1) at water in/out temperature 20/15 °C, glycol 0 %, either 25 °C ambient temperature (air-cooled models) or 25 °C condenser water inlet temperature with 35 °C condensing temperature (water-cooled models)

2) at water in/out temperature 12/7 °C, glycol 0 %, 32 °C ambient temperature (air-cooled models)

3) referred to axial fan version in free field conditions at a distance of 10 m from until, measured on condenser side, 1 m from ground

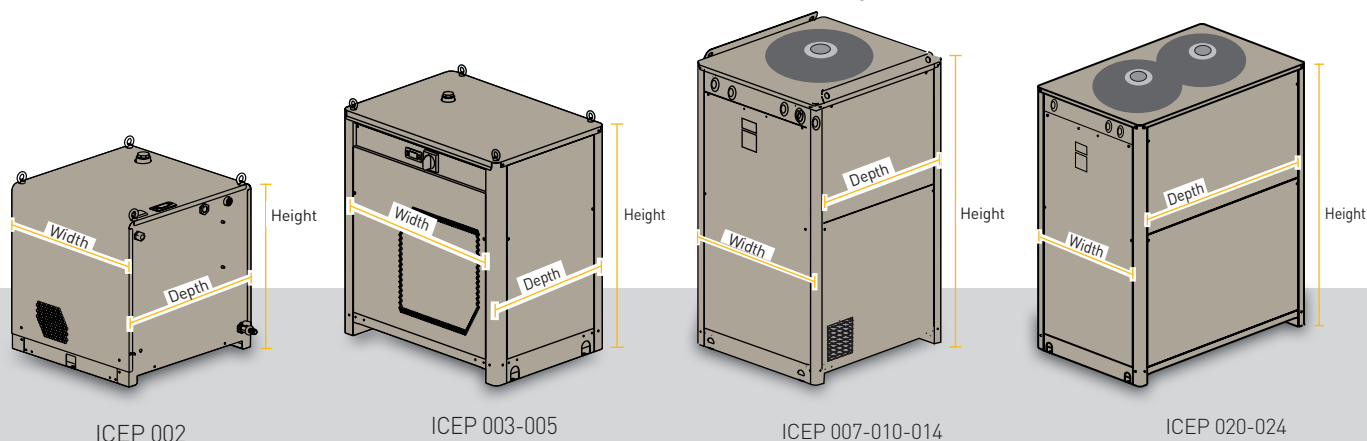

Product Specification

Hyperchill Plus Water Range

Correction factors

A) Ambient temperature correction factor (f1)	°C	5	10	15	20	25	30	35	40	45
		1,05	1,05	1,05	1,05	1	0,94	0,89	0,84	0,80
B) Water outlet temperature correction factor (f2)	°C	5	10	15	20	25	30	35	40	45
		0,76	0,87	1	1,04	1,04				
C) Glycol (by weight) correction factor (f3)	%	0	10	20	30	40				
		1	0,99	0,98	0,97	0,96				
D) Condenser Water inlet temp. correction factor (f4)	°C	20	25	30	35	40				
		1,05	1	0,95	0,9	0,85				

To obtain the required cooling capacity, multiply the value at nominal conditions by the above correction factors (i.e. cooling capacity = $P \times f1 \times f2 \times f3 \times f4$, where P is the cooling capacity at the water outlet temperature of 15 °C). Hyperchill Plus, in its standard configuration, can operate up to ambient temperatures of max. 48 °C and min. 5 °C and water temperatures of max. 30 °C inlet and min. 0 °C outlet. The above correction factors are approximative: for a precise selection, always refer to the software selection programme.

Options

	ICEP002-W	ICEP003-W	ICEP005-W	ICEP007-W	ICEP010-W	ICEP014-W	ICEP020-W	ICEP024-W
No Tank	✓	✓	✓	✓	✓	✓	✓	✓
No Tank & NO Pump	✓	✓	✓	✓	✓	✓	✓	✓
No Pump	✓	✓	✓	✓	✓	✓	✓	✓
P50	✓	✓	✓	✓	✓	✓	✓	✓
P15				✓	✓	✓	✓	✓
Harting Plug	✓	✓	✓	✓	✓	✓	✓	✓
Close Control (+/-0,5 °C)		✓	✓	✓	✓	✓	✓	✓
Low Water				✓	✓	✓	✓	✓
Fan Speed Control				✓	✓	✓	✓	✓
Low Ambient -20 °C				✓	✓	✓	✓	✓
Anti-Freeze Heating				✓	✓	✓	✓	✓
BioEnergy				✓	✓	✓	✓	✓
Differential Dynamic Set Point				✓	✓	✓	✓	✓
Tropicalization (53 °C, without ambient fill kit)						✓	✓	✓
Siemens Electrical Components (no control)	on request							

Versions

Open Circuit (with ambient fill tank)	✓	✓	✓					
Closed Circuit			✓	✓	✓	✓	✓	✓
Water cooled (plate condenser)						✓	✓	✓

Accessories

Water fill kits: non-ferrous pressurized, automatic or ambient manual kits, for water filling in any installation.

Remote control kits: base version for remote ON/OFF and general alarm monitoring. Advanced version for complete remote unit monitoring.

Wheels (ICEP002 - ICEP014): for ease of transport.

Water filters: for circuit cleanliness and machinery protection.

Water by-pass: non-ferrous, externally adjustable allowing the correct flow through the system to be set.

Control panel cover: from ICEP007, can be supplied already installed.

EMEA Product Information Centre

Free phone: 00 800 27 27 5374

(from AT, BE, CH, CZ, DE, DK, EE, ES, FI, FR, IE, IL, IS, IT, LU, MT, NL, NO, PL, PT, RU, SE, SK, UK, ZA)

US Product Information Centre

Toll-free number: 1-800-27 27 537

www.parker.com/hzd

Your local authorized Parker distributor