



Rotary Screw Compressors

DSDX Series

With the world-renowned SIGMA PROFILE

Flow rate 4.8 to 34.25 m³/min, Pressure 5.5 to 15 bar

DSDX series

KAESER KOMPRESSOREN pushes the boundaries of compressed air efficiency and availability once again with its latest generation of **DSDX** series rotary screw compressors. Intelligent design solutions have not only led to enhanced ease of operation and serviceability, but also give this series of class-defining compressors their distinctive modern appearance.

DSDX: The multi-saver

Delivering improved specific power, the flow-optimised and further refined SIGMA PROFILE rotors provide the basis for exceptional energy efficiency. The use of high performance IE4 drive motors maximises energy efficiency, whilst KAESER's 1:1 drive design eliminates the transmission losses associated with gear or V-belt driven systems, as the motor directly drives the airend. Furthermore, the radial fan fulfils the efficiency requirements for fans as per EU directive 327/2011. Last, but not least, the advanced SIGMA CONTROL 2 compressor controller achieves additional energy savings and minimises cost-intensive idling periods through the use of a variety of specially developed control options, e.g. Dynamic control.

Service-friendly = Efficient

The distinctive and eye-catching design of these systems from the outside is complemented by intelligent component layout on the inside for even greater energy efficiency: for example, all service and maintenance points are within easy reach and directly accessible from the front of the unit. This not only saves time and money, but also maximises compressed air system availability.

Perfect partners

DSDX series rotary screw compressors are the perfect partners for high-efficiency industrial compressed air stations. The internal SIGMA CONTROL 2 compressor controller offers numerous communications interfaces (e.g. Ethernet), which, when connected within the KAESER SIGMA NETWORK, allows seamless communication with advanced master controllers, such as KAESER's SIGMA AIR MANAGER, and in-house centralised control systems. This enables simple set-up and achieves unprecedented levels of efficiency.

Electronic Thermal Management

Powered via an electric motor, the sensor-controlled temperature control valve integrated into the cooling circuit is the heart of the innovative Electronic Thermal Management (ETM) system. The SIGMA CONTROL 2 compressor controller monitors intake and compressor temperature in order to prevent condensate formation, even under conditions with higher air humidity. ETM dynamically controls the fluid temperature and low fluid temperature enhances energy efficiency. DSDX packages are equipped with a second ETM system if the heat recovery option is chosen. This enables heat recovery to be better adapted to the customer's exact requirements.

Why choose heat recovery?

The question should in fact be: Why not? Amazingly, up to 100 percent of the (electrical) energy input to a compressor is converted into heat. Up to 96 % of this energy can be recovered and reused for space heating or hot water production purposes. This not only reduces primary energy consumption, but also significantly improves the operational total energy balance.

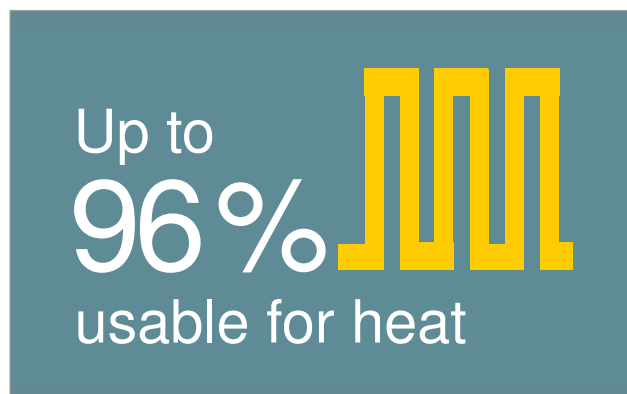

Up to
96%
usable for heat

Intrinsic value for optimum efficiency: DSDX series rotary screw compressors



Image: DSDX 305, air-cooled



DSDX – Detailed design for maximum energy savings



SIGMA PROFILE

At the heart of every DSDX system lies a premium quality airend featuring KAESER's SIGMA PROFILE rotors. Operating at low speed, KAESER's airends are equipped with flow-optimised rotors for superior efficiency.



SIGMA CONTROL 2: optimum efficiency

The internal SIGMA CONTROL 2 controller always ensures efficient control and monitoring of compressor operation. The large display and RFID reader provide easy communication and maximum security. Multiple interfaces enable seamless networking capability, whilst the SD card slot makes updates quick and easy.



The future, today: IE4 motors

KAESER is currently the only compressed air systems provider to equip its compressors with super premium efficiency IE4 motors as standard, thereby delivering maximum performance and energy efficiency.



Correct temperature assured

The innovative Electronic Thermal Management (ETM) system dynamically controls fluid temperature to provide reliable prevention of condensate accumulation. This enhances energy efficiency, for example, by enabling heat recovery to be precisely tailored to meet customers' exact needs.



Efficient in every way



Dependable condensate separation

Integrated as standard, the KAESER axial centrifugal separator with electronic ECO-DRAIN condensate drain provides an exceptionally high degree of separation (>99 %) with minimal pressure loss. Dependable and efficient condensate separation is therefore assured at all times, even under conditions with high ambient temperatures and humidity.



Environmentally-friendly fluid filter

The Eco filter elements housed in the aluminium fluid filter enclosure are 'metal-free'. They can therefore simply be disposed of thermally at the end of their service life.



Service-friendly

Just like the air filter, which is simple to change from the front of the unit, all other maintenance components are also easy to access. Quicker maintenance and service work tasks reduce operating costs and increase availability.



External lubrication

Electric motors must be lubricated while running. In DSDX compressors, service staff can easily perform this task from the outside of the machine. This applies to both the compressor drive motor and the fan motors.



Clever cooling, significant savings



Low operating temperature

Thermostat controlled fans with variable speed motors produce the exact amount of cooling air required to ensure low operating temperatures. This significantly reduces the overall energy demand of DSDX rotary screw compressor systems.



Low compressed air temperature

Effective aftercooling helps maintain low compressed air discharge temperature. This, in combination with the centrifugal separator, removes large volumes of condensate which is then drawn off without energy loss via the electronically controlled ECO-DRAIN condensate drain. In turn, the burden on downstream treatment equipment is also reduced.



Coolers cleaned from the outside

Unlike internally installed radiators, the externally installed coolers in DSDX systems are easy to access and simple to clean. Operational reliability and availability are therefore enhanced, as contaminant build-up is easily spotted.

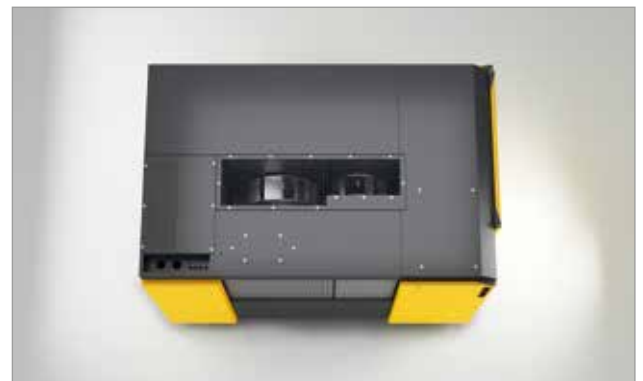

High residual thrust exhaust air

The integrated radial fans are considerably more efficient than axial fans and provide high residual thrust. This generally enables the warm exhaust air to be directly ducted away without the need for an auxiliary fan.



Compressor with variable speed drive

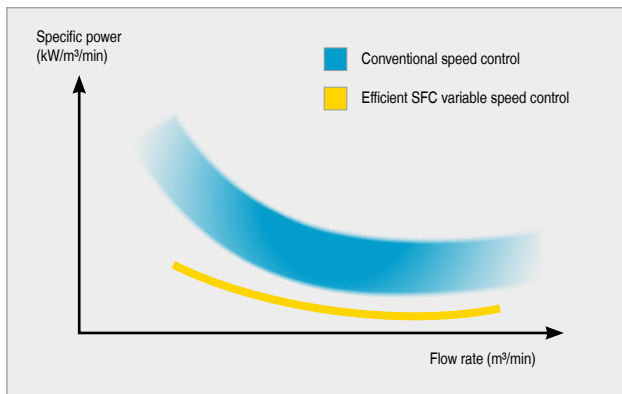

Optimised specific power

The variable speed rotary screw compressor is the most heavily loaded piece of equipment in a compressor station. DSDX-SFC models are therefore designed to provide maximum efficiency without running at extreme speeds. This saves energy, maximises service life and enhances reliability.

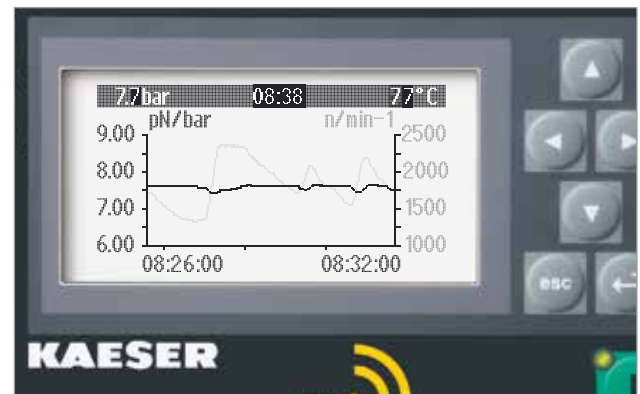

Consistent pressure

The volumetric flow rate can be adjusted within the control range according to pressure to suit actual compressed air demand. As a result, operating pressure is precisely maintained to within ± 0.1 bar. This allows maximum pressure to be reduced which saves both energy and money.



Separate SFC control cabinet

The SFC (SIGMA FREQUENCY CONTROL) variable speed drive is housed in its own control cabinet to shield it from heat from the compressor. A separate fan keeps operating temperatures in the optimum range to ensure maximum performance and service life from the SFC unit.



EMC-certified

It goes without saying that the SFC control cabinet and SIGMA CONTROL 2 are tested and certified both as individual components and as a complete system to EMC directive EN 55011 for Class A1 industrial power supplies.

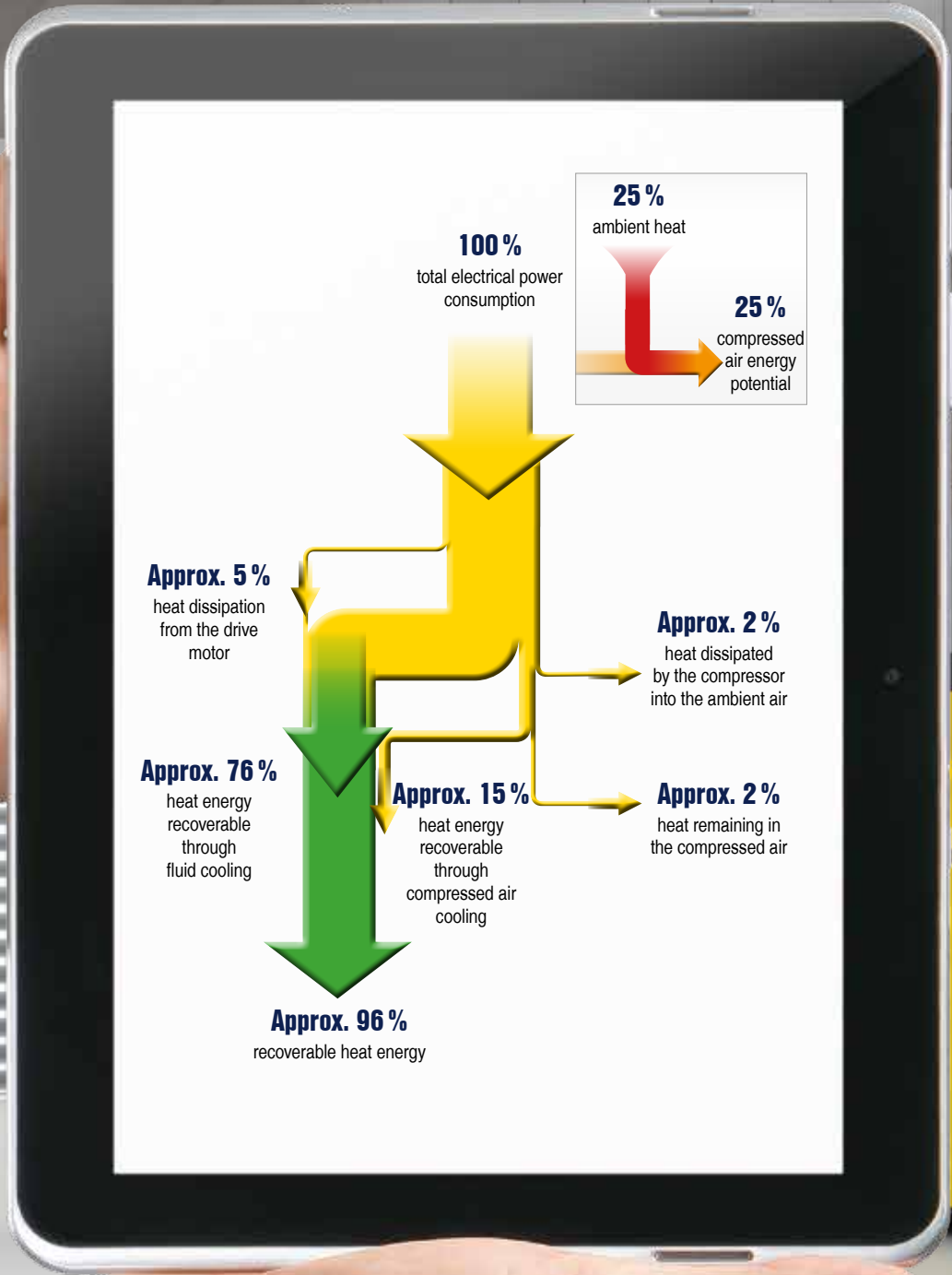

Savings calculation example for warm air heat recovery in terms of fuel oil (DSDX 305)

Maximum available heat capacity:	176 kW	
Fuel value per litre of fuel oil:	9.861 kWh/l	
Fuel oil heating efficiency:	0.9	
Price per litre of fuel oil:	0.70 €/l	1 kW = 1 MJ/h x 3.6
Cost saving:	$\frac{176 \text{ kW} \times 2000 \text{ h}}{0.9 \times 9.861 \text{ kWh/l}}$	x 0.70 €/l = € 27,763 per year

Further information regarding heat recovery:
http://www.kaeser.com/Products_and_Solutions/Rotary-screw-compressors/heat-recovery/

Heat recovery – energy from compression

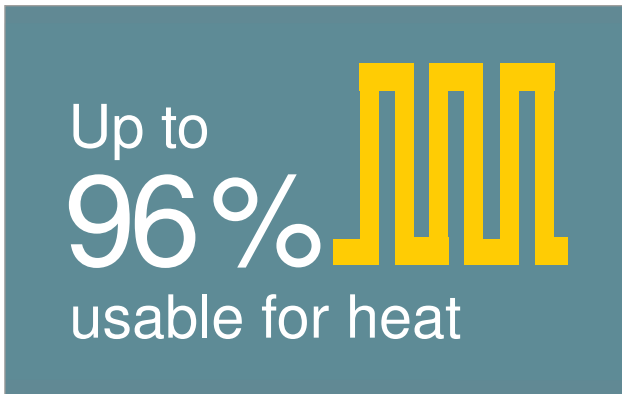

Heat recovery a win

Amazingly, 100 % of the electrical drive energy input to a compressor is converted into heat energy. From that, up to 96 % is available for heat recovery purposes. Use this potential to your advantage!



Space heating with warm exhaust air

It's heating made easy: thanks to the high residual thrust radial fan, exhaust (warm) air can be easily ducted away to spaces that require heating. This simple process is thermostatically controlled.

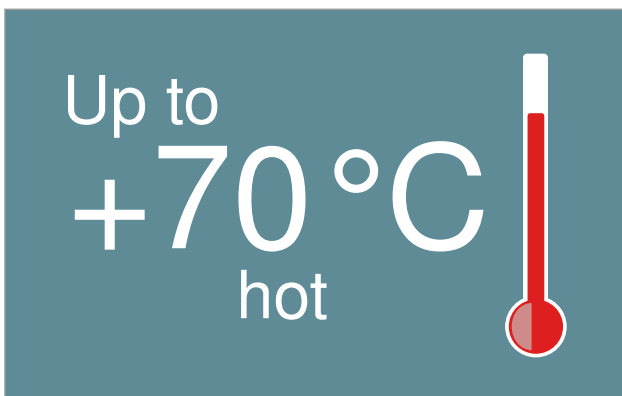

Process, heating and service water

Hot water – up to 70 °C – can be produced from reusable compressor heat via an optional plate-type heat exchanger system. The ETM system enables the temperature to be adjusted to the customer's individual requirements. Moreover, heat recovery system activation and deactivation is made possible via the SIGMA CONTROL 2.



Systems for hot water usage

The integrated system comprising the plate heat exchanger, thermostatic valve and complete pipework requires no additional space in the compressor and can recover 76 % of the overall power consumption of DSDX compressors by utilising the heat in the water.

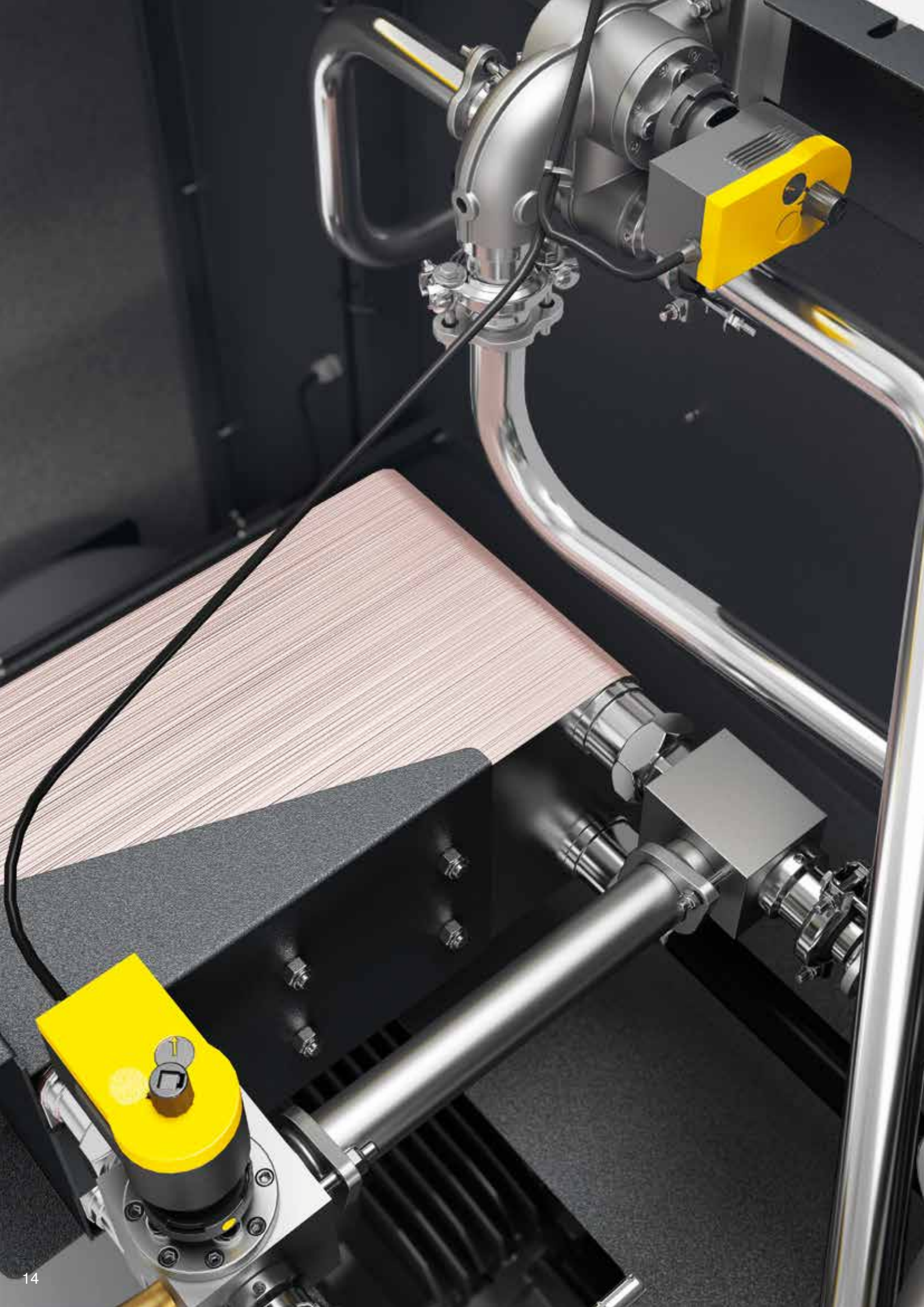

Heat recovery – energy-saving, versatile, flexible



Dual Thermal Management

DSDX packages with integrated heat recovery are equipped with two electromotive temperature control valves (ETM), one for the heat recovery system and one for the package oil cooler.



Flexible temperature

The SIGMA CONTROL 2 controller enables precision setting of the required airoend discharge temperature of the compressed air needed in order to achieve the desired water discharge temperature from the heat recovery system.



Save energy with the SIGMA CONTROL 2

If all of the heat energy is drawn-off by the heat recovery system, then the SIGMA CONTROL 2 recognises that cooling is no longer required on the package cooler and, as a result, the fan on the oil cooler is shut off. This achieves further energy savings.



Winter ON – Summer OFF

If no heat recovery is required, such as in the summer months for example, this can be simply deactivated using the SIGMA CONTROL 2: under ETM control, the package immediately starts to operate once again at maximum energy efficiency with lowest possible airoend temperature.

Equipment

Complete unit

Ready for operation, fully automatic, silenced, vibration damped, all panels powder coated. Can be used in ambient temperatures up to +45 °C. Service-friendly design: bearings for drive and fan motors can be lubricated externally.

Airend

Genuine KAESER single-stage rotary screw airend with energy-saving SIGMA PROFILE rotors and cooling-fluid injection for optimised rotor cooling, 1:1 direct drive.

Fluid and air flow

Dry air filter with pre-separation, inlet silencer, pneumatic inlet and venting valve, cooling fluid reservoir with three-stage separation system; pressure relief valve, minimum pressure check valve, Electronic Thermal Management (ETM) and eco fluid filter in cooling circuit, fluid and compressed air aftercooler (air-cooled as standard); two fan motors (one with variable speed control); KAESER centrifugal separator with electronically controlled condensate drain (high efficiency and zero pressure loss); stainless steel pipework and centrifugal separator.

Water-cooled version (Option)

Fluid and compressed air aftercooler implemented as water-cooled plate or optionally available tube-type heat exchanger.

Optimised separator system

The combination of flow-optimised pre-separation and special separator cartridges results in minimal remaining fluid content of < 2 mg/m³ in the compressed air. This separator system requires less maintenance.

Heat recovery (Option)

Optionally available with integrated fluid/water plate-type heat exchanger and equipped with additional thermostatic valve for fluid; exterior connections.

Electrical components

Premium efficiency IE4 drive motor with three PT 100 coil temperature sensors for motor monitoring, ventilated IP 54 control cabinet, automatic star-delta protection combina-

tion, overload relay, control transformer, variable speed fan motor on oil cooler. Frequency converter for drive motor with SFC version.

SIGMA CONTROL 2

“Traffic light” LED indicators show operational status at a glance, plain text display, 30 selectable languages, soft-touch keys with icons, fully automated monitoring and control. Selection of Dual, Quadro, Vario, Dynamic and continuous control as standard. Interfaces: Ethernet; additional optional communication modules for Profibus DP, Modbus, Profinet and Devicenet. SD-card slot for data-logging and updates; RFID reader, web server.

Efficient Dynamic Control

Dynamic Control feature calculates run-on times based on the motor winding temperature. This reduces idling times and energy consumption. Additional control options are stored in the SIGMA CONTROL 2 and can be called up as required.

SIGMA AIR MANAGER 2 (SAM 2)

The further-refined Adaptive 3-D^{advanced} Control predictively calculates and compares various operating scenarios and selects the most efficient to suit the compressed air application's specific needs, which enables compressor flow rate and energy consumption to be precisely adjusted to match actual compressed air demand. In combination with the integrated multi-core processor industrial PC, the Adaptive 3-D^{advanced} Control is able to ensure optimised performance at all times. Furthermore, the SIGMA NETWORK bus converters (SBC) provide a host of possibilities to enable the system to be individually tailored to meet exact user requirements. The SBC can be equipped with digital and analogue input and output modules, as well as with SIGMA NETWORK ports, to enable seamless display of flow rate, pressure dew point, power or alarm message information.

Amongst other key features, the SIGMA AIR MANAGER 2 provides long-term data storage capability for reporting, controlling and audits, as well as for energy management tasks as per ISO 50001.

(See image to the right; excerpt from the SIGMA AIR MANAGER 2 brochure)



Digital output device, e.g. laptop



Control centre

KAESER CONNECT



SIGMA AIR MANAGER 2

Communications module e.g. Modbus TCP

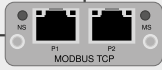

KAESER SIGMA NETWORK

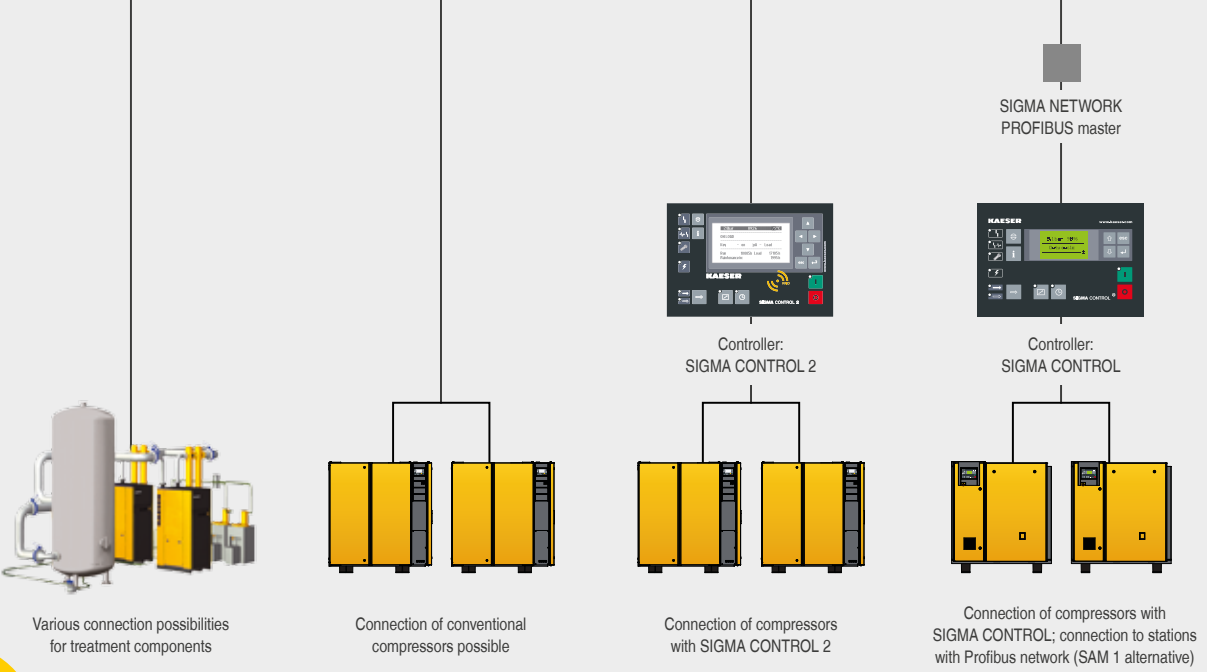

Secure data – secure business!

Technical specifications

Version

Model	Working pressure	Flow rate *) overall machine at working pressure	Max. working pressure	Nominal motor power	Dimensions W x D x H	Connection Compressed air	Sound pressure level **)	Mass
	bar	m ³ /min	bar	kW	mm		dB(A)	
DSDX 245	7.5	25.15	8.5	132	2690 x 1910 x 2140	DN 80	74 68 ***)	3950
	10	20.40	12					
	13	16.15	15					
DSDX 305	7.5	30.20	8.5	160	2690 x 1910 x 2140	DN 80	75 69 ***)	4450
	10	24.70	12					
	13	19.78	15					



SFC - Version with variable speed drive

Model	Working pressure	Flow rate *) overall machine at working pressure	Max. working pressure	Nominal motor power	Dimensions W x D x H	Connection Compressed air	Sound pressure level **)	Mass
	bar	m ³ /min	bar	kW	mm		dB(A)	
DSDX 245 SFC	7.5	5.57 - 27.17	8.5	132	2940 x 1910 x 2140	DN 80	75 70 ***)	4700
	10	4.95 - 23.35	12					
	13	4.95 - 19.27	15					
DSDX 305 SFC	7.5	6.85 - 33.03	8.5	160	2940 x 1910 x 2140	DN 80	76 71 ***)	4800
	10	5.35 - 28.46	12					
	13	5.18 - 24.01	15					



*) Flow rate complete system as per ISO 1217: 2009 Annex C: Absolute inlet pressure 1 bar (a), cooling and air inlet temperature 20 °C

**) Sound pressure level as per ISO 2151 and basic standard ISO 9614-2, tolerance: ± 3 dB (A)

***) Sound pressure level for water-cooled version

How it works

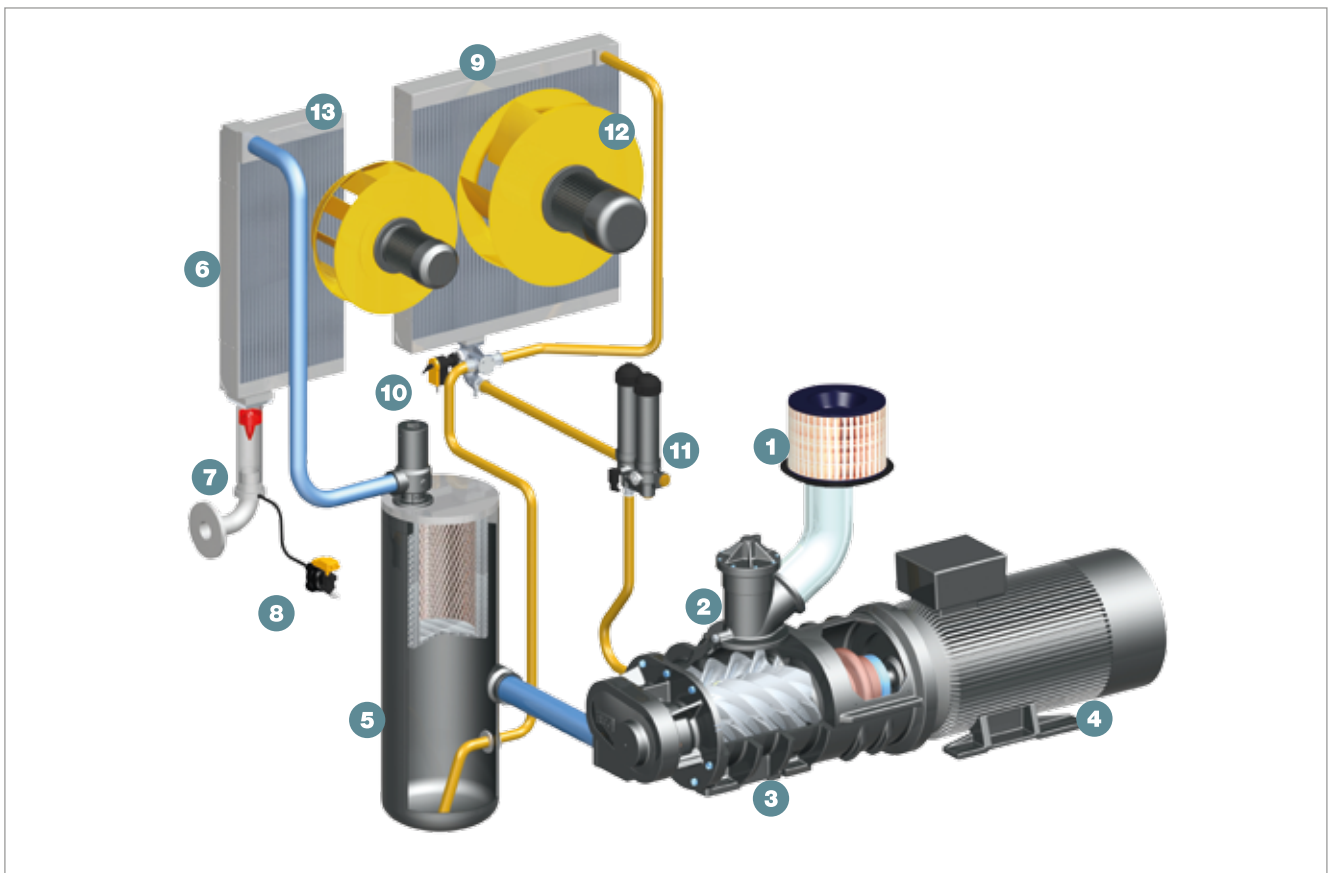

The rotary screw airend (3) is driven by an electric motor (4). The fluid injected primarily for cooling purposes during the compression process is separated once again from the air in the fluid separator (5). The integrated fan ensures cooling of the compressor package and also provides sufficient flow of cooling air through the oil cooler and compressed air aftercooler (6 and 9).

The controller ensures that the compressor produces compressed air within the set pressure limits. Safety functions protect the compressor against failure of key systems by automatically shutting it down.

- (1) Intake filter
- (2) Intake valve
- (3) SIGMA PROFILE airend
- (4) IE4 drive motor
- (5) Fluid separator tank
- (6) Compressed air aftercooler
- (7) KAESER centrifugal separator
- (8) ECO-DRAIN condensate drain
- (9) Fluid cooler
- (10) Electronic Thermal Management
- (11) Eco fluid filter
- (12) Fluid cooler radial fan with variable speed control
- (13) Compressed air aftercooler radial fan

The world is our home

As one of the world's largest compressed air systems providers and compressor manufacturers, KAESER KOMPRESSOREN is represented throughout the world by a comprehensive network of branches, subsidiary companies and authorised partners.

With innovative products and services, KAESER KOMPRESSOREN's experienced consultants and engineers help customers to enhance their competitive edge by working in close partnership to develop progressive system concepts that continuously push the boundaries of performance and compressed air efficiency. Moreover, the decades of knowledge and expertise from this industry-leading system provider are made available to each and every customer via the KAESER group's global computer network.

These advantages, coupled with KAESER's worldwide service organisation, ensure that every product operates at the peak of its performance at all times and provides maximum availability.



HPC | Compressed
Air Systems

HPC Compressed Air Systems, Victoria Gardens, Burgess Hill, West Sussex RH15 9RQ
Tel: 01444 241671 Fax: 01444 247304 E-Mail: info@hpcplc.co.uk www.hpccompressors.co.uk